

General Description

Series HP50 pilot pressure valves are designed to provide a separately mounted, pilot pressure system for solenoid and hydraulic remote-controlled, directional control valves.

The pilot pressure valve is installed in the hydraulic system between the pump and the directional control valve.

This valve can be used for other applications where a pilot pressure is required. Possible applications are remote-controlled, variable displacement pumps or motors and differential locks.

The valve consists of a mechanical sequence valve and a pressure reducing cartridge. The pilot operated sequence valve creates a stand-by pressure greater than the pressure reducing cartridge. The pressure reducing cartridge limits the maximum pressure in the pilot circuit.

Features

- Eliminates separate pilot pump and relief valve for a pilot system
- Simplifies plumbing for a pilot system
- Easily installed into an existing hydraulic system
- Optional main system relief valve available
- Solenoid kits available

Operation

The mechanical pressure build up valve can be used in open center systems where the pump is not in stand-by operation for long periods of time. Pilot pressure is maintained at all times.

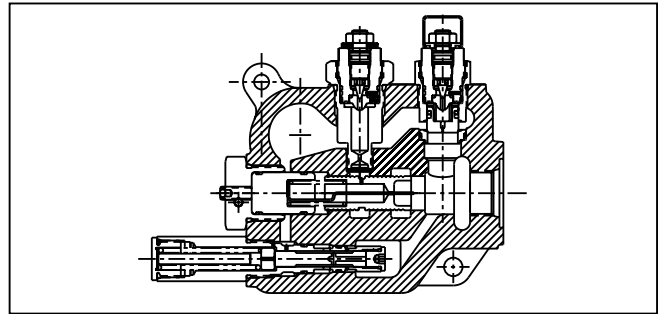
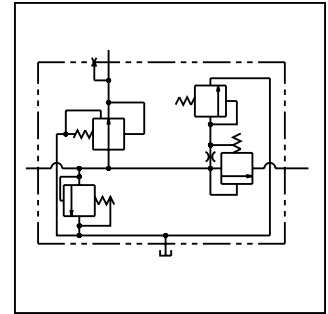
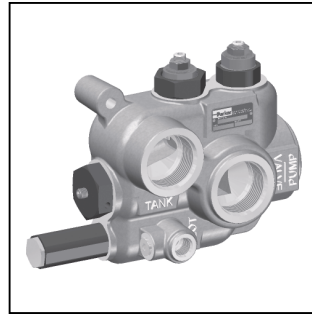
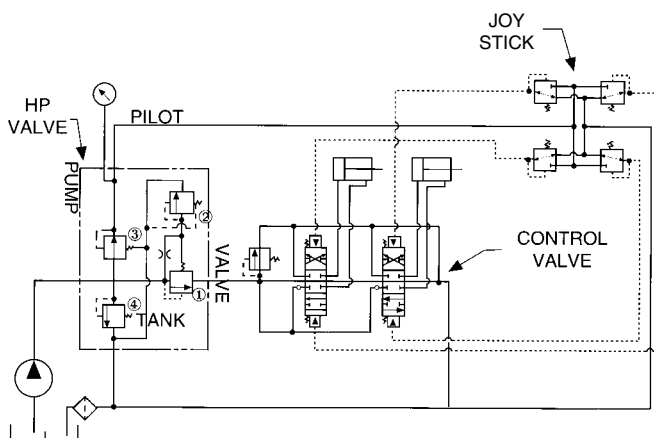

Specifications

Input Flow	187.5 LPM (50 GPM)
Pilot Flow	18.75 LPM (5 GPM)
Operating Pressure Inlet Tank	240 Bar (3500 PSI) 24 Bar (350 PSI)
Operating Temperature Range (Ambient)	Nitrile Seals: -40°C to +93°C (-40°F to +200°F)
Material	Body – High strength cast iron
Filtration	ISO Code 16/13, SAE Class 4 or better
Mounting Position	In-line; no restrictions

Understanding the HP pilot pressure valve

Many open center systems have very little pressure drop through the directional valve when in the neutral position. These systems do not provide enough pressure for pilot operation. To create pilot pressure, use the HP valve.

The HP valve has four basic component parts:

1. Sequence valve slave
2. Sequence valve pilot
3. Reducing valve
4. Relief valve

The sequence slave (part #1) and the sequence pilot (part #2) create the back pressure that is used for pilot operation. The reducing valve (part #3) protects the pilot system from high pressure. The relief valve (part #4) protects the pump. Note that the relief valve is located on the pump side of the sequence valve.

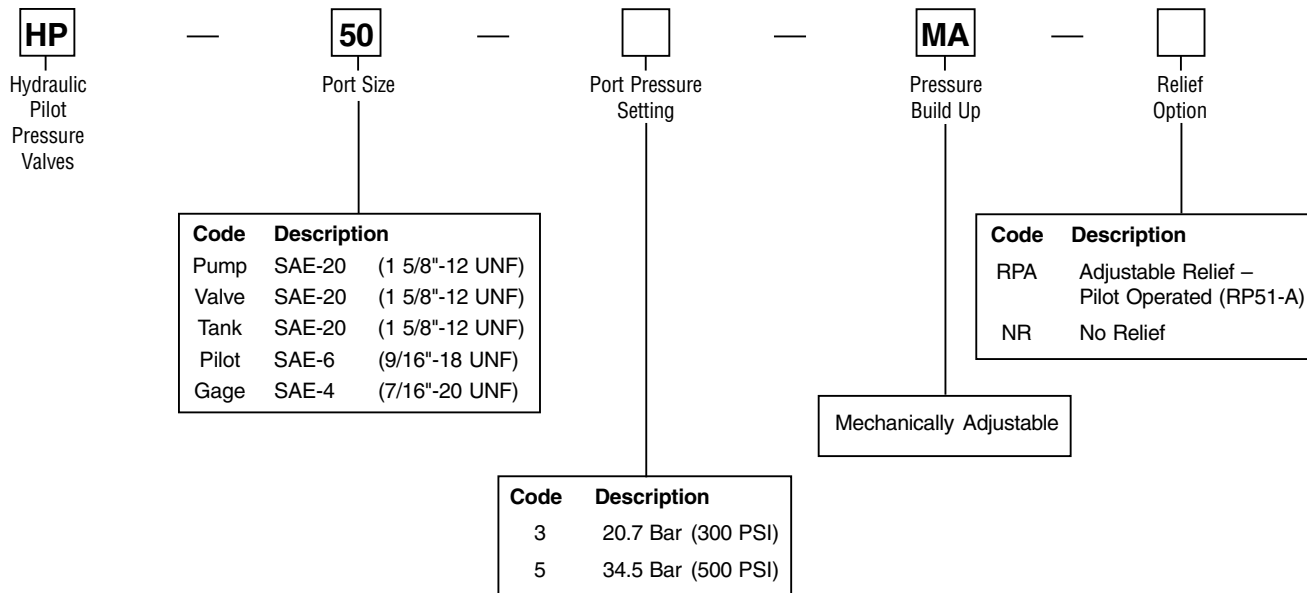

Service Parts

20.7 Bar (300 PSI) Pilot Pressure Reducing Valve	11416001
34.5 Bar (500 PSI) Pilot Pressure Reducing Valve	11416002
NR - no relief plug	04142003
Relief Valve	RP51-A
Pressure Build Up Valve	20275001
Upper Seal - Pressure Build Up Valve	3914V-9
Lower Seal - Pressure Build Up Valve	2019N-7
Lower Back Up Ring - Pressure Build Up Valve	407480
12 VDC Solenoid Unloader Kit	10722001
24 VDC Solenoid Unloader Kit	00711871
Relief Valve Seal Kit	00712223

Note: The body and the internal parts are non-service items.

Dimensions

Inch equivalents for millimeter dimensions are shown in (**)

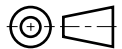
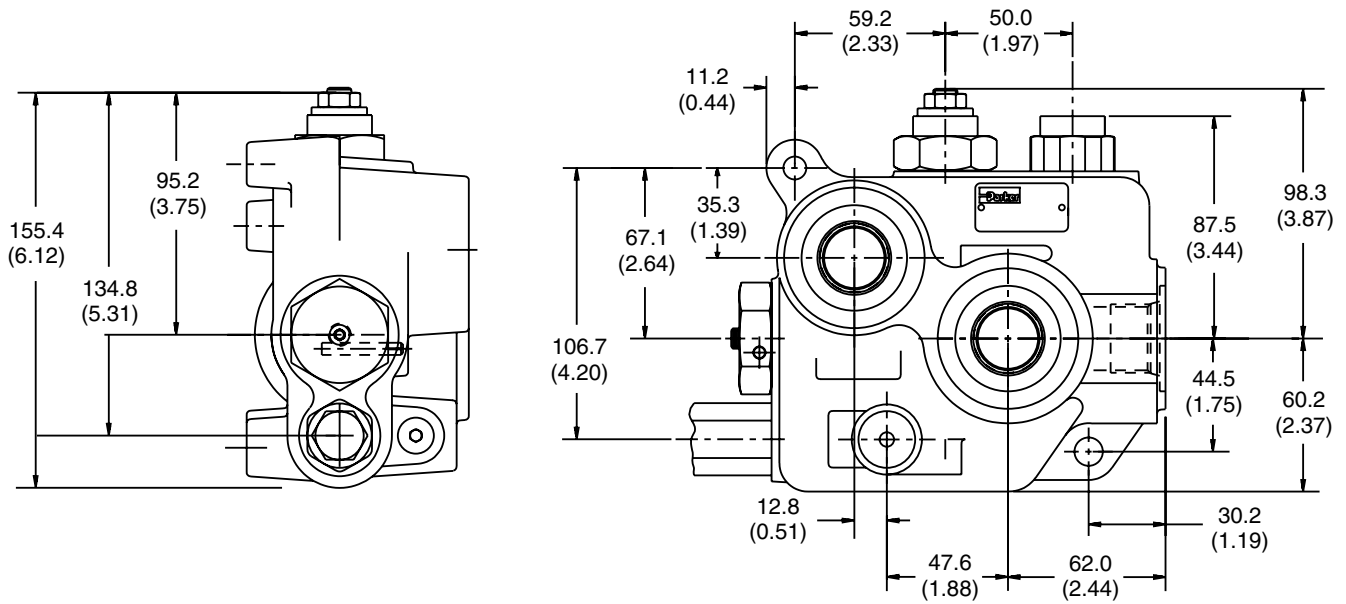

Performance Curve

